

# HCA

## High-Speed Passenger Elevator Planning Guide

The information in this catalogue is subject to change without notice. The information and diagram in this catalogue reflect the technical feature and configuration of the elevator model at press time (refer to the version number). In line with the principle of continuous development of products, our company reserves the right to change the selection of product technical parameters and colour at any time. The existing image technology cannot accurately reproduce the elevator component structure and decoration colour. Therefore, this catalogue only provides general information, not as a contract document. The specific configuration parameters are subject to the formal agreement.

If you need detailed information, please contact us.

02 Specification  
 03 Layout  
 04 FI System  
 07 Elevator Function  
 09 Overhead Height and Pit Depth  
 10 Hoistway and Machine Room  
 15 Entrance Design  
 17 Electrical Information  
 18 Electrical Data  
 19 Civil Works Matters

Load (kg)	No. of Passengers ①	Speed (m/min)	Maximum Number of Stops	Maximum Travel (m)	Maximum Travel with Fireman Operation (m)	Minimum Floor Height (mm)
825	11	180/210/240	64	200	180m/min:160 210m/min:185 240m/min:200	2800
900	12	180/210/240				
1050	14	180/210/240				
1150	15	180/210/240				
1350	18	180/210/240				
1600	21	180/210/240				
1800	24	180/210/240				
2000	26	180/210/240	64	210	210	2800
1050	14	300				
1150	15	300				
1350	18	300				
1600	21	300		200	200	

Note:  
 ① Passenger numbers calculated at 75kg per person.  
 ② The information above are based on GB standards.

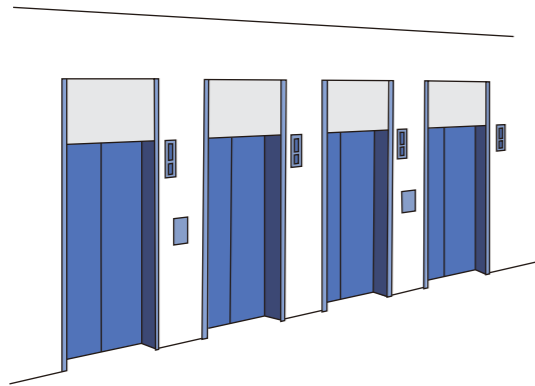

- Maximum in-line arrangement is 4 elevators.
- Elevators in different groups should not be set in the same line.
- Avoid placing the elevators entrance near pillars.

- More than 5 units in the same group, the elevators should be set face-to-face. And the distance of facing elevators(L) should be 3.5~4.5m.
- Different group elevators with face-to-face arrangement, the distance of facing elevators(L) should be more than 6m.

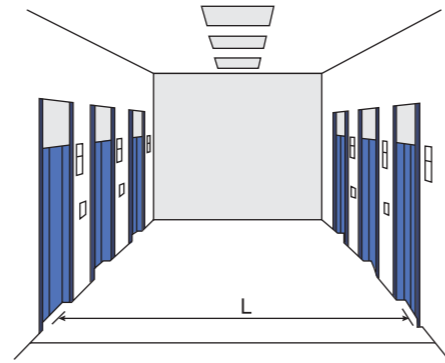

- Elevators in same group should have same stops.
- Elevators in same group should be set the same floor as basement and not recommend to set several entrance.

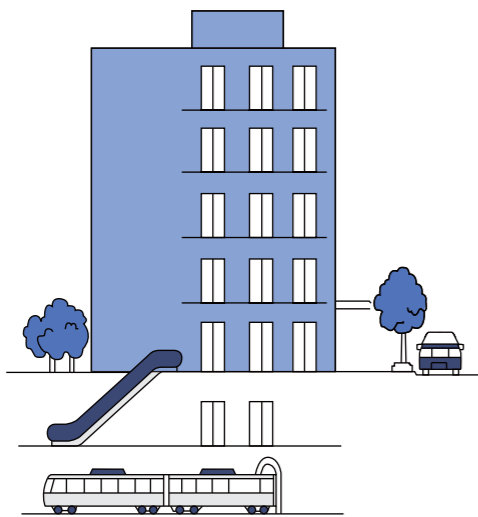

## <FI-600 Features> Future Reference-Trajectory Control

A group control system groups multiple elevators for achieving a well-balanced operation by taking waiting times into account. Such a system requires flexibility so that it can be used in various types and sizes of buildings and be responsive to changing traffic demand.

(FI-600)	(FI-100)	(FI-10)
(3-8 Cars)	(3-6 Cars)	(3-4 Cars)
Allows a flexible control for elevator car allocation and the required number of cars according to the congestion state in the building and the type of building.	Elevator cars are allocated at equal time intervals according to "Reference-Trajectory Control" for shortening the average waiting times and reducing the probability of a long wait.	Provides a ring control to allocate the elevator car closest to the floor where a new hall call is registered.

Basic Specification	Instantaneous reservation and service forecasting		
	Intelligent function		
	Generation of new traffic flow modes Generation of optimum operation programs		
	Congested floor recognition		
	Learning function		
	<ul style="list-style-type: none"> <li>• Collection of usage data</li> <li>• Recognition of traffic flow mode (40/2 modes)</li> <li>• Search for optimum operation program</li> </ul>		
	Arrival notice indication (hall lantern and chimes)		
	Bunching prevention ①		
	Future reference-trajectory control	Reference-trajectory control	Ring control
	Forecasting dynamic allocation control	Zone distribution control	Fixed floor distribution control
System name	<b>FI-600</b>	<b>FI-100</b>	<b>FI-10</b>
Recommended number of cars in a group	3~8 cars	3~6 cars	3~4 cars
Type of building	Large office buildings and hotels	Small office building, department stores, hotels and hospitals	Building with small traffic demand
Optional	VIP service, independent automatic operation		
	Service floor selection		
	Destination floor reservation system Centralized control for special floors Zoning express service		

Note:

① Bunching prevention: Using the "future reference-trajectory control" or the "reference-trajectory control" in the FI-600 or FI-100, elevator cars are operated at equal time intervals to prevent local bunching.

## Basic Function

● : Basic spec. ▲ : Option spec. — : Not applicable

No.	Item	Content	FI-600	FI-100	FI-10
1	Instantaneous reservation and service forecasting (FI-HRF)	Upon receipt of a hall call, this function activates and elevator to serve this call, and at the same time the call is acknowledged by the hall lantern and chime.	●	—	—
2	Arrival notice indication (FI-ANI)	Four to five seconds prior to the arrival of an elevator, this function will activate the hall lantern flickering and the chime sound.	●	●	▲
3	Basic call assignment control	Future reference-trajectory control (FI-FRTC)	●	—	—
		Reference-trajectory control (FI-RTC)	—	●	—
4	Personalized control	Through the hall call assignment control of waiting time priority assignment, constantly carry out operation management in accordance with waiting time priority.	●	●	—
	Waiting time priority assignment	Prevent long waiting time of passengers by implementation of hall call assignment.	●	●	—
	Riding time priority assignment	Prevent long riding time of passengers by implementation of hall call assignment.	▲	▲	—
	Bunching prevention (FI-BP)	This function prevents local bunching of elevator cars using the "future reference-trajectory control" or the "reference-trajectory control" for operating cars at equal time intervals.	●	●	—
5	Learning function	Collection of usage data (FI-CUD)	●	●	—
		Recognition of traffic flow mode (FI-RTM)	● (40 modes)	● (2 modes)	—
		Search for optimum operation program (FI-SOP)	●	●	—
6	Congested floor recognition (FI-CFR)	Identifies congested floors according to the usage data learned in each traffic flow mode.	●	—	—
7	Service forecasting for hall call assignment (FI-SFH)	This function assigns elevator cars to hall calls more precisely by forecasting the arrival time and number of passengers in the car according to the learning-based traffic demand.	●	—	—
8	Intelligent function	Generation of new traffic flow modes (FI-GNT)	●	—	—
		Generation of optimum operation programs (FI-GOP)	●	—	—
9	Energy saving preference control (FI-ESC)	This system reduces the number of elevator cars in service when traffic demand is low.	●	—	—
10	Floor standby control	Forecasting dynamic allocation control (FI-FDA)	●	—	—
		Zone distribution control (FI-ZD)	—	●	—
		Fixed floor distribution (FI-FD)	—	—	●

## Basic Function

● : Basic spec. ▲ : Option spec. — : Not applicable

No.	Item	Content	FI-600	FI-100	FI-10
11	Learning based concentrated service (FL-LCS)	Centralizes the service to the learning-based congested floors during peak times including morning, lunch time and evening peaks while taking the service for other floors into account.	●	—	—
12	Rush-hour schedule operation	All the elevators will automatically return to the start floor after serving the last call during this preset rush-hour timing.	●	—	▲
13	Destination floor priority control	The allocation will be priority when the destination floor and the hall call is the same floor.	●	●	—
14	Full car forecasting control	Control the new allocation according to the number of passengers in car and the times of new calls.	●	●	—
15	Full car control	Stop new allocation or re-allocate the car when full load.	●	●	—
16	Long waiting time allocation control	Re-allocate the cars when long waiting time situation is forecasted.	●	●	—
17	Notice function	Keep the service elevator car door open with hall lantern flickering to guide the passengers.	▲	●	—
18	Automatic door open time control (FI-ADT)	This function automatically controls the duration of the door open time according to the floor and the kind of call (hall call or car call) as well as the elevator condition.	●	●	—

## Operating Function

No.	Item	Content	FI-600	FI-100	FI-10
1	Centralized control for special floors (FI-CCF)	This function preferentially assigns an elevator to the special floor. (e.g. the director's room)	▲	—	—
2	Service floor selection (FI-SFS) [Floor lock-out operation]	Allows the operator to select the service and non-service floors using, for example, the switches on the control panel.	▲	▲	—
3	VIP service (FI-VIP)	When welcoming or sending off important guest, this function permits an elevator to be summoned directly to the desired car call floor by pushing a specially provided switch.	▲	▲	▲
4	DFRS	Each passenger registers their destination floor on the registration device located at the landing hall and know in advance the designated elevator to take. System assigned one elevator for the passengers with the same destination floor. This helps to reduce congestion in the elevator lobby and improve efficiency.	▲	—	—
5	Zoning express service (FI-EZS)	Start a divided express service when the peak traffic demand takes place in the present time zones.	▲	—	—

## Man-machine Function

No.	Item	Content	FI-600	FI-100	FI-10
1	Malicious operation cancelled function	Cancel the allocation when system identifies the call is malicious.	●	●	—
2	Hall information (FI-HI)	General and elevator operation information is indicated on the LED or LCD hall indicator.	—	—	●

# Elevator Function

## Standard Function

Control System			
SA1	Simplex Collective Control	SA2	Floor Height Self Measurement
SA3	On-Cage (Car Top) Maintenance Operation	SA4	In-Cage Slow Speed Operation
SA5	Machine-Room Debugging Operation Function		
System Protection			
SB1	Over Speed Electrical Protection	SB2	Overspeed Mechanical Protection
SB3	Rope Slipping Running Protection	SB4	Motor Overload (Thermal) Protection
SB5	Automatic Fault Detection	SB6	Automatic Fault Recording
SB7	Standby Regular Auto-Check	SB8	Double Brake-Safety Check Operation
SB9	Synchronous Motor Magnetic Pole Static Test	SB10	Lift-Position Abnormally Auto-Correction Function
SB11	Nearest Landing Operation	SB12	Anti-electromagnetic Interference
Safe Communication			
SC1	Interphone System (5 Ways)		
Safe Riding			
SD1	Out of Door-Open Zone Alarm	SD2	Alarm System
SD3	Door Safety Return System	SD4	Full Load Bypass Operation
SD5	Overload Detection System	SD6	Overload Alarm
SD7	Next Drive (Door Open Abnormity)	SD8	Door Opening/Closing Time Abnormity Protection
SD9	Automatic Door Dwell Time Control	SD10	Automatic Door Dwell Time Adjustment
SD11	Number of Runs Indicator	SD12	Multi-Beam Protection ①
SD13	Inspection Indication in Hall Indicator	SD14	Current Floor Push-Button Reopening Function ①
SD15	Overload Indicator (In Car)	SD16	Emergency Terminal Stopping Device, ETSD (For 300m/min)
Emergency Solution			
SE1	Car Emergency Lighting	SE2	Fire Emergency Operation (Automatic)
Design for Comfort			
SF1	Parking Operation	SF2	Automatic Return Function
SF3	Start Torque Auto-Adjustment	SF4	Door-Stop Function (Maintenance)
SF5	Micro Levelling (Travel ≥45m)	SF6	Advance Door Opening
SF7	Mischievous Call Cancellation	SF8	Opposite Direction Car Call Cancellation
SF9	Car Light Auto Turn-off	SF10	Car Fan Auto Turn-off
SF11	Abnormal Duration Hall Call Detection ① (Applicable for Simplex, Duplex and FI-10 only.)	SF12	Car Floor Button Flashing ①
SF13	Car Call Deselect Function	SF14	Step-less Speed Control
SF15	Regenerative System Function	SF16	Door Bypass Detection
SF17	Overload Hall Call Recovery Function (Not applicable for FI-100 and FI-600.)	SF18	Base Floor Selection (Applicable for Simplex only.)
SF19	Car Call Limitation		

Note:  
① Details, please contact us.

# Elevator Function

## Optional Function

Control System			
OA1	Simplex Down Collective Control	OA2	Duplex Collective Control
OA3	Duplex Down Collective Control	OA4	FI-10 ①
OA5	FI-100 ①	OA6	FI-600 ①
OA7	Independent Automatic Operation ①	OA8	VIP Service
OA9	Rush Hour Schedule Operation (Not applicable for FI-100)		
Safe Communication			
OB1	Contact at Control Panel (RS485)	OB2	Elevator Monitoring System (Computer Type)
OB3	Supervisory Panel (Dry Contact Type)	OB4	Twisted Pair Cable (1 pair) for CCTV
OB5	Twisted Pair Cable (1 pair) for BGM Interface	OB6	Contact at Control Panel (Dry Contact)
OB7	Camera Device Inside the Car		
Safe Riding			
OC1	Multi-Beam + Safety Edge Protection	OC2	Card Reader Interface (In Car) (RS485) ① (Not applicable when OE5 is selected.)
Emergency Solution			
OD1	Fireman Operation (Load≥825kg)	OD2	Automatic Rescue Device (ARD) (Maximum travel distance ≤30m)
OD3	EM. Operation for Power Failure (Manual)	OD4	EM. Operation for Power Failure (Auto)
OD5	Earthquake Emergency Operation	OD6	Pit Flood Operation
OD7	Emergency Terminal Stopping Device, ETSD (For HCA 210~240m/min)		
Design for Comfort			
OE1	Attendant Operation	OE2	Independent Operation
OE3	Voice Synthesizer	OE4	Arrival Chime (Car Top and Bottom)
OE5	Floor Lock Out Operation ① (Not applicable when OC2 is selected.)	OE6	Door Opening Prolong Button
OE7	Hall Call Registration in Car Operating Panel (Applicable when OE1 is selected)	OE8	Sub Car Operating Panel
OE9	Double Opening Function ① (Not applicable for FI-100, FI-600 and FI-10 (>48 stops.)	OE10	Horizontal Car Operating Panel
OE11	Braille Button	OE12	EMC ①
OE13	Operation Status Indication at Hall Indicator	OE14	DFRS (Under FI-600)
OE15	Hall Call Deselect Function ① (Applicable for Simplex, Duplex and FI-10 only.)		

Note:  
① Details, please contact us.

# Overhead Height and Pit Depth

# Hoistway and Machine Room (Standard Car Design, Counterweight Location: Rear)

Load (kg)	Speed (m/min)	Overhead Height OH (mm)		Pit Depth P (mm)		
		Travel < 100m	100m < Travel ≤ 200m	Travel < 100m	100m ≤ Travel ≤ 150m	150m < Travel ≤ 200m
825	180	5500	5500	2890	3170	3170
	210	5790	5790	3070	3360	3360
	240	6190	6190	3920	3920	3920
900	180	5500	5500	2890	3170	3170
	210	5790	5790	3070	3360	3360
	240	6190	6190	3920	3920	3920
1050	180	5500	5500	2910	3190	3270
	210	5910	5790	3090	3380	3460
	240	6190	6190	3920	3920	3970
1150	180	5500	5500	2910	3190	3270
	210	5910	5790	3090	3380	3460
	240	6190	6190	3920	3920	3970
1350	180	5500	5500	2940	3220	3300
	210	5790	5790	3120	3410	3490
	240	6190	6190	3920	3920	3970
1600	180	5500	5500	2940	3300	3430
	210	5790	5790	3120	3490	3620
	240	6190	6190	3970	3970	4120
1800	180	5500	5500	2970	3460	3460
	210	5790	5790	3150	3650	3650
	240	6190	6190	4120	4120	4120
2000	180	5500	5500	2970	3460	3460
	210	5790	5790	3150	3650	3650
	240	6190	6190	4120	4120	4120

Load (kg)	Speed (m/min)	Overhead Height OH (mm)		Pit Depth P (mm)
		Travel ≤ 200m	200m < Travel ≤ 210m	
1050	300	5740	5900	3580
1150	300	5740	5900	3580
1350	300	5740	5900	3580
1600	300	5600	—	3730

- Note:
- The information and dimensions above are based on GB standards.
  - Configuration is based on rear counterweight arrangement without counterweight safety gear.
  - The information above is based on decoration weight provision up to 300kg (For load 1050kg & 1150kg) and 500kg (For load ≤ 900kg & load ≥ 1350kg).
  - The overhead height above is based on bare ceiling height of 2450mm (For Speed ≤ 240m/min) and 2600mm (For Speed = 300m/min).
  - The pit depth above is based on standard vinyl tile finish without floor recess.

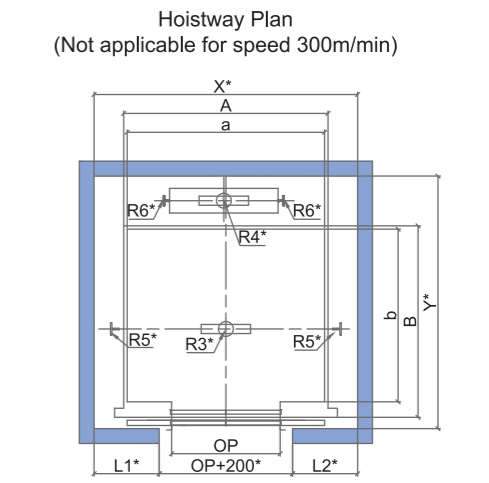
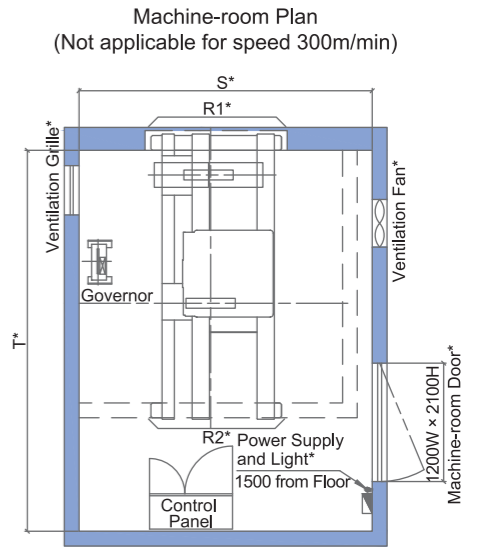
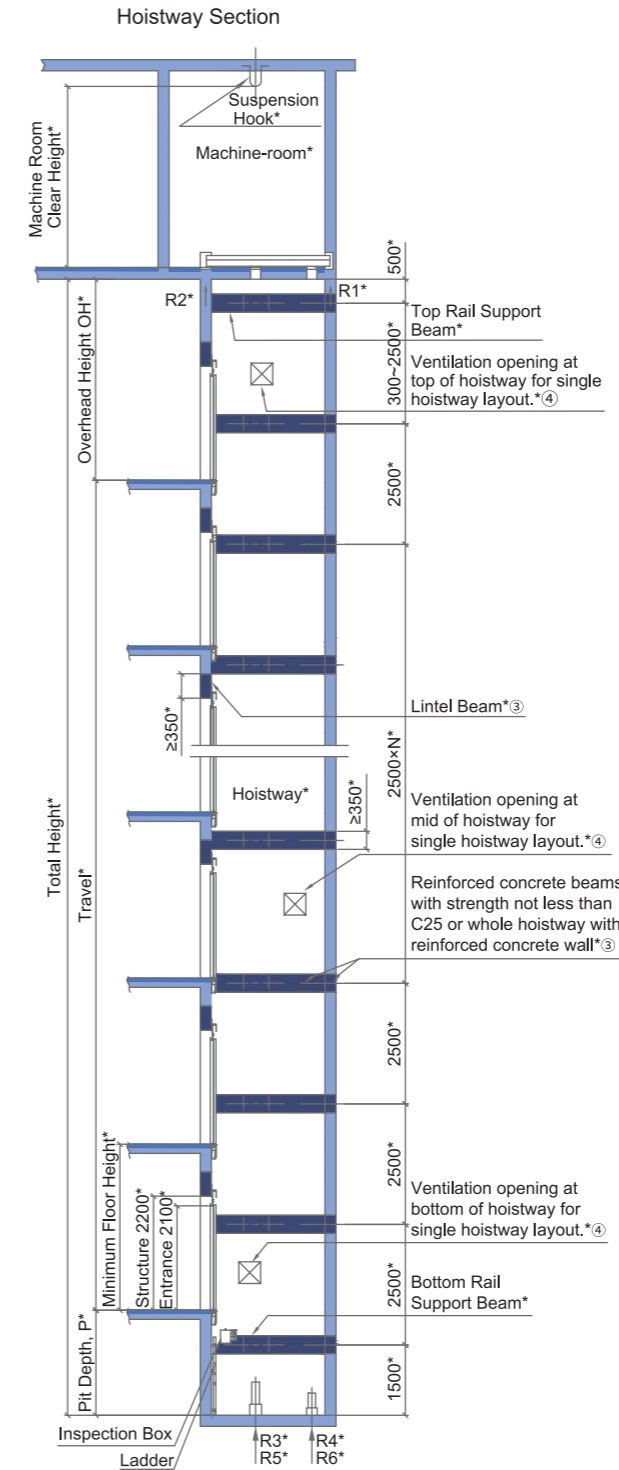

- Note:
- Items with "\*" shall be furnished by building contractors.
  - Hoistway shall not be located next to bedrooms, classroom, ward, library or any other places where low noise is required.
  - The hoistway construction shall be reinforced concrete ring beam with strength C25 or whole hoistway of reinforced concrete wall. If you have other situations, please contact us.
  - For hoistway and machine room details, please contact us.
  - Unit of dimension shall be in mm unless otherwise stated.

Load (kg)	Speed (m/min)	Machine-room Clear Height (mm)	Suspension Hook Capacity (Tons)
825/900/1050/1150/1350/1600/1800/2000	180/210/240	2500	4
1050/1150/1350/1600	300	2500	4

# Hoistway and Machine Room

(Standard Car Design, Counterweight Location: Rear)

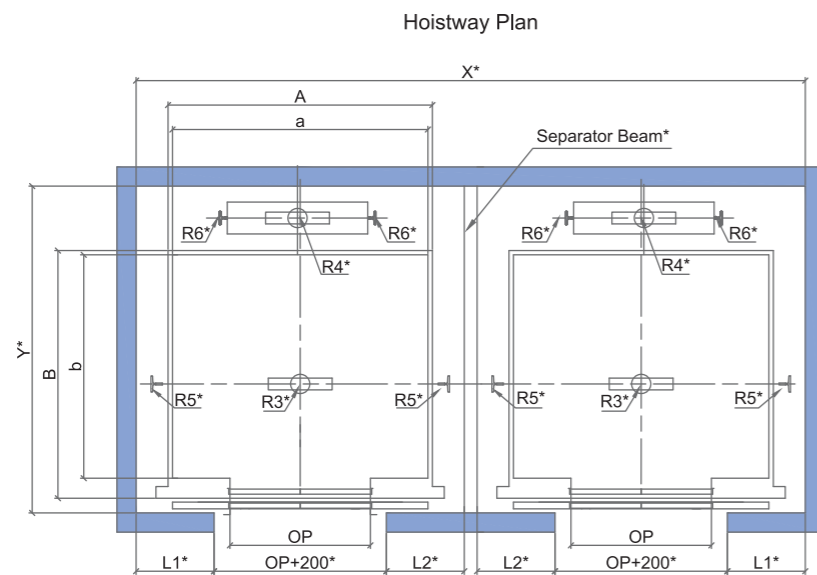
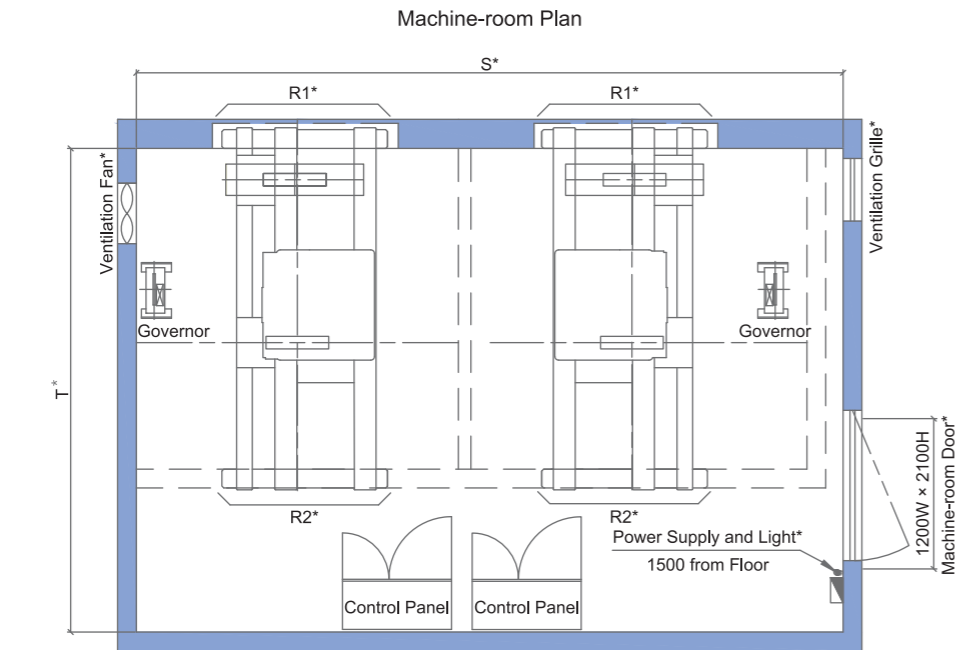

- Note:
- ① Items with "\*" shall be furnished by building contractors.
  - ② Hoistway shall not be located next to bedrooms, classroom, ward, library or any other places where low noise is required.
  - ③ The hoistway construction shall be reinforced concrete ring beam with strength C25 or whole hoistway of reinforced concrete wall. If you have other situations, please contact us.
  - ④ For hoistway and machine room details, please contact us.
  - ⑤ Unit of dimension shall be in mm unless otherwise stated.

# Hoistway and Machine Room

(Standard Car Design, Counterweight Location: Rear)

Load (kg)	Speed (m/min)	Car Size (mm)		Door Opening (mm)		Front Wall Arrangement (mm)		Hoistway (mm)		Machine Room (mm)		Reaction Loading (KN)					
		Internal (a×b)	External (A×B)	Type	Width	L1	L2	X×Y		S×T		Machine Room		Pit			
								Single	Double	Single	Double	R1	R2	R3	R4	R5	R6
825	180	1400×1350	1470×1540	2P-CO	800	475	475	1950×2150	4050×2150	2400×3450	4950×3450	155	105	250	225	110	40
	210																
	240																
900	180	1600×1350	1670×1540	2P-CO	900	525	525	2150×2150	4450×2150	2500×3450	5150×3450	160	105	260	240	110	40
	210																
	240																
1050	180	1600×1500	1670×1690	2P-CO	900	525	525	2150×2300	4450×2300	2500×3600	5150×3600	160	110	270	250	115	40
	210																
	240																
1150	180	1800×1500	1870×1690	2P-CO	1000	575	575	2350×2300	4850×2300	2600×3600	5350×3600	170	115	280	260	130	40
	210																
	240																
1350	180	2000×1500	2070×1690	2P-CO	1100	625	625	2550×2300	5250×2300	2690×3600	5530×3600	180	125	300	275	135	40
	210																
	240																
1600	180	2000×1700	2070×1890	2P-CO	1100	625	625	2550×2500	5250×2500	2690×3800	5530×3800	190	125	310	280	135	40
	210																
	240																
1800	180	2200×1700	2270×1890	2P-CO	1200	675	675	2750×2500	5650×2500	2800×3800	5750×3800	210	135	335	300	135	40
	210																
	240																
2000	180	2200×1850	2270×2040	2P-CO	1200	675	675	2750×2650	5650×2650	2800×3950	5750×3950	210	140	335	300	135	40
	210																
	240																

- Note:
- ① The information and dimensions above are based on GB standards.
  - ② Hoistway dimension for double elevators are based on 150mm width separator beam.
  - ③ Configuration is without counterweight safety gear.

# Hoistway and Machine Room

(Standard Car Design, Counterweight Location: Rear)

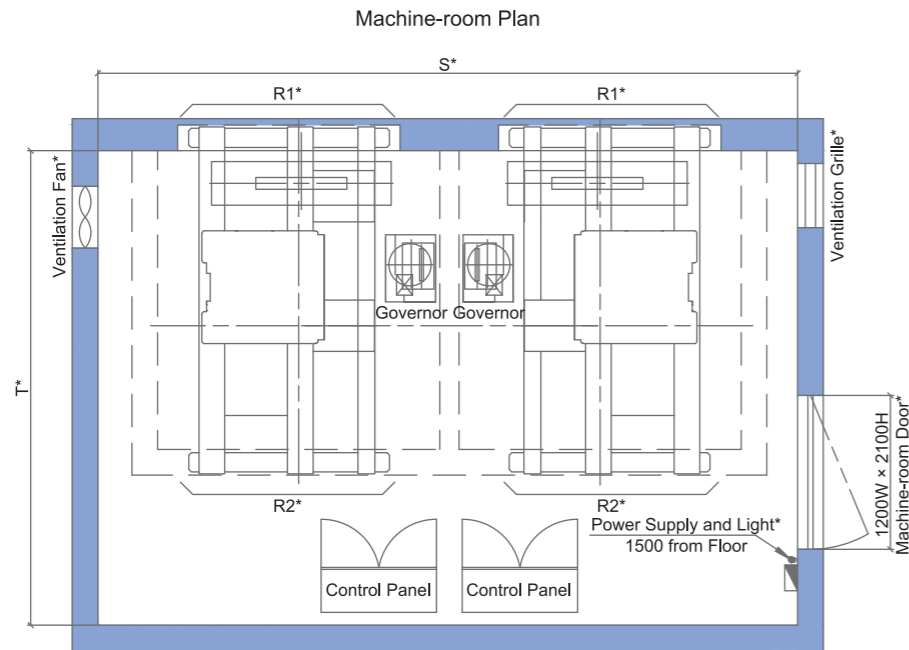

Machine-room Plan

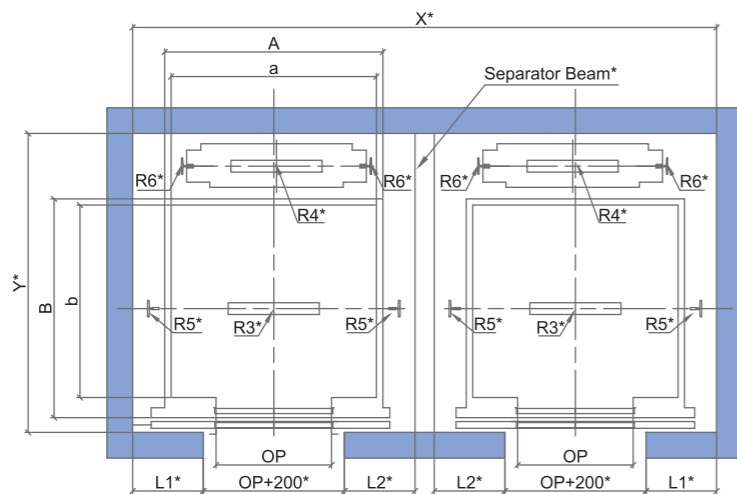

Hoistway Plan

- Note:
- ① Items with "\*" shall be furnished by building contractors.
  - ② Hoistway shall not be located next to bedrooms, classroom, ward, library or any other places where low noise is required.
  - ③ The hoistway construction shall be reinforced concrete ring beam with strength C25 or whole hoistway of reinforced concrete wall. If you have other situations, please contact us.
  - ④ For hoistway and machine room details, please contact us.
  - ⑤ Unit of dimension shall be in mm unless otherwise stated.

# Hoistway and Machine Room

(Standard Car Design, Counterweight Location: Rear)

Load (kg)	Speed (m/min)	Car Size (mm)		Door Opening (mm)		Front Wall Arrangement (mm)		Hoistway (mm)	Machine Room (mm)	Reaction Loading (KN)					
		Internal (a×b)	External (A×B)	Type	Width	L1	L2			Machine Room		Pit			
								X×Y	S×T	R1	R2	R3	R4	R5	R6
1050	300	1600×1500	1700×1705	2P-CO	900	550	550	4550×2330	5455×3700	210	145	310	280	130	50
1150	300	1800×1500	1900×1705	2P-CO	1000	600	600	4950×2330	5610×3700	210	145	310	280	130	50
1350	300	2000×1500	2100×1705	2P-CO	1100	650	650	5350×2330	5850×3700	210	145	310	280	135	50
1600	300	2000×1700	2100×1905	2P-CO	1100	650	650	5350×2530	5850×3900	210	145	310	280	135	50

- Note:
- ① The information and dimensions above are based on GB standards.
  - ② Hoistway dimension for double elevators are based on 150mm width separator beam.
  - ③ Configuration is without counterweight safety gear.



## Elevation of Entrance

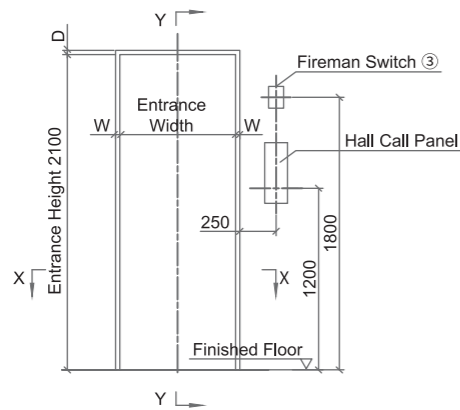

For Entrance With Fireman Switch

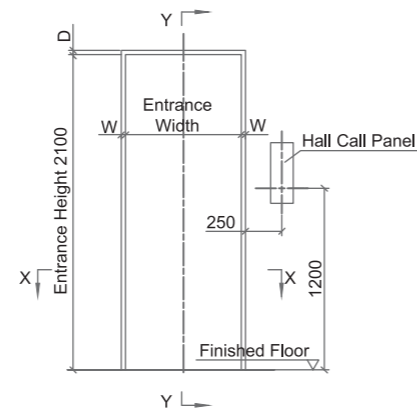

For Entrance Without Fireman Switch

## Structure Opening of Entrance ①

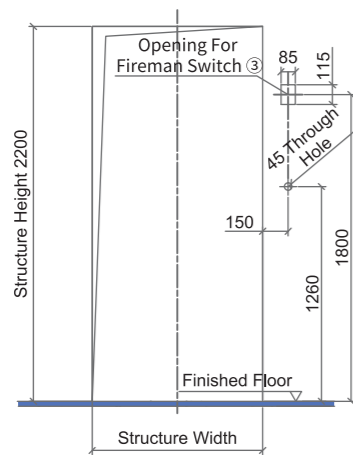

For Entrance With Fireman Switch

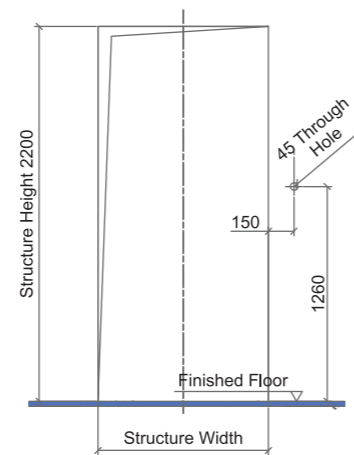

For Entrance Without Fireman Switch

Type	AS-1X	SS-1X
W	10	25
D	10	25

- Note:
- ① Structural opening of entrance shall be furnished by building contractor.
  - ② Unit of dimension shall be in mm unless otherwise stated.
  - ③ Applicable only when fireman operation function with fireman switch is located at lift landing.

The followings shall be furnished by building contractors:

- Building Structure
- Wall and Floor Finishes
- Grouting Work

## Narrow Jamb (AS-1X)

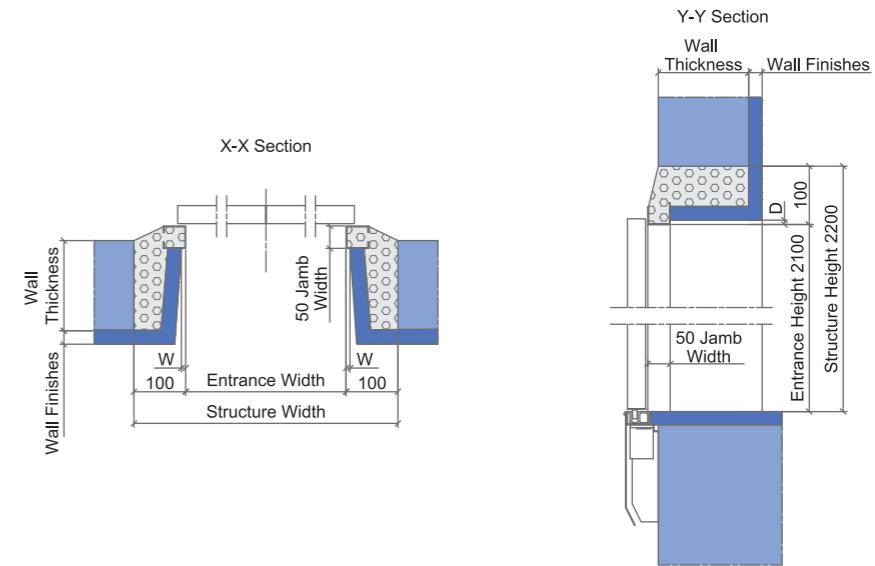

## Wide Jamb (SS-1X)

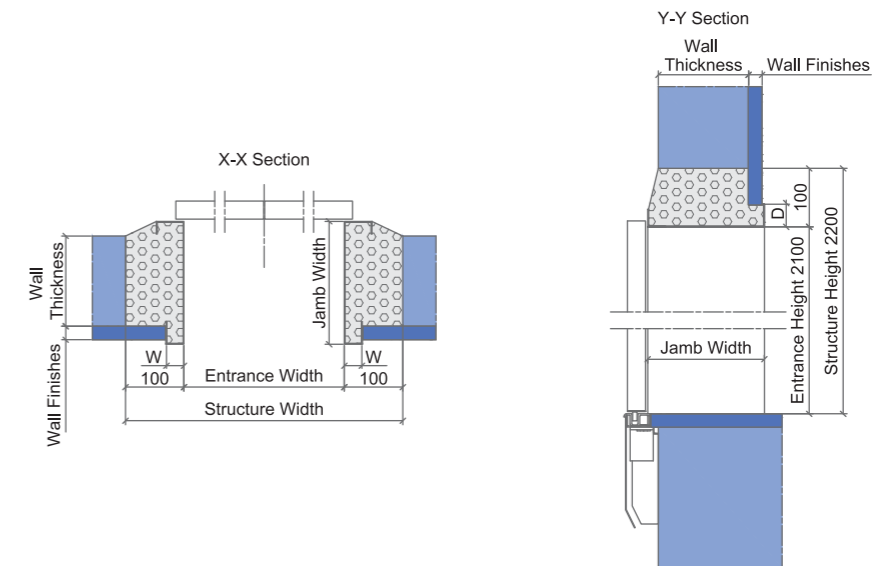

# Electrical Information

The followings shall be furnished by building contractors:

~~~~~ Electrical Equipment

— Cable

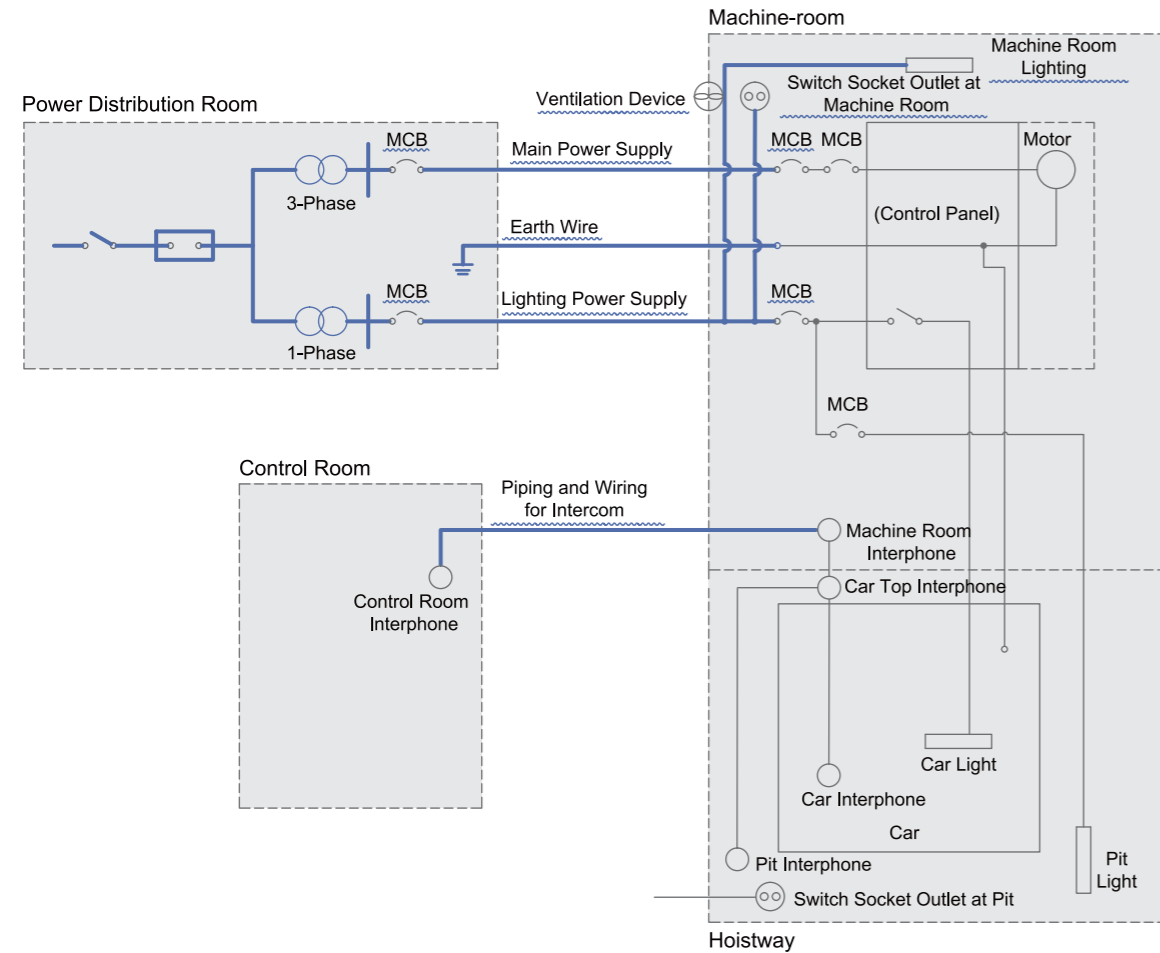

Note:  
 ① Main Power Supply: Three-phase, five wires system, AC380V 50Hz  
 ② Lighting Power Supply: Single-phase, three wires system, AC220V 50Hz

| Item                            | Works to be provided by building contractor                                                                                                                    |
|---------------------------------|----------------------------------------------------------------------------------------------------------------------------------------------------------------|
| Main Power Supply               | To provide power supply switch around the entrance of machine room. To install facilities to ensure that power supply voltage fluctuation shall be within ±7%. |
| Lighting Power Supply           | To provide lighting power supply for car lighting, fan and indicator.                                                                                          |
| Ventilation Device              | To provide mechanical ventilation to the machine room to ensure that the temperature in the machine room is maintained at below 40°C.                          |
| Pit light, Switch Socket Outlet | To provide single phase AC 220V, 10A switch socket outlet and pit lighting with switch below the entrance floor level for maintenance purposes.                |

# Electrical Data

| No. | Load (kg) | Speed (m/min) | Voltage                  | Circuit Breaker Capacity (A) |         | Transformer Capacity (kVA) |         | Main Power Wire Size (mm <sup>2</sup> ) |         | Earth Wire Size (mm <sup>2</sup> ) |         | Machine Room Ventilation        |
|-----|-----------|---------------|--------------------------|------------------------------|---------|----------------------------|---------|-----------------------------------------|---------|------------------------------------|---------|---------------------------------|
|     |           |               |                          | 1 unit                       | 2 units | 1 unit                     | 2 units | 1 unit                                  | 2 units | 1 unit                             | 2 units | Ventilation Fan Size Dia (Ø mm) |
| 1   | 825       | 180           | 3Φ380V<br>1Φ220V<br>50Hz | 75                           | 100     | 18                         | 30      | 30                                      | 50      | 16                                 | 25      | 350                             |
|     |           | 210           |                          | 75                           | 125     | 20                         | 34      | 30                                      | 60      | 16                                 | 30      | 350                             |
|     |           | 240           |                          | 75                           | 125     | 23                         | 38      | 35                                      | 80      | 16                                 | 40      | 350                             |
| 2   | 900       | 180           |                          | 75                           | 100     | 19                         | 33      | 30                                      | 50      | 16                                 | 25      | 350                             |
|     |           | 210           |                          | 75                           | 125     | 22                         | 37      | 35                                      | 60      | 16                                 | 30      | 350                             |
|     |           | 240           |                          | 75                           | 125     | 24                         | 41      | 35                                      | 80      | 16                                 | 40      | 400                             |
| 3   | 1050      | 180           |                          | 75                           | 125     | 22                         | 37      | 35                                      | 60      | 16                                 | 30      | 350                             |
|     |           | 210           |                          | 75                           | 125     | 25                         | 41      | 35                                      | 80      | 16                                 | 40      | 400                             |
|     |           | 240           |                          | 75                           | 160     | 27                         | 46      | 50                                      | 80      | 25                                 | 40      | 400                             |
| 4   | 1150      | 300           |                          | 125                          | 180     | 36                         | 56      | 60                                      | 125     | 30                                 | 63      | 350×2                           |
|     |           | 180           |                          | 75                           | 125     | 23                         | 39      | 35                                      | 80      | 16                                 | 40      | 400                             |
|     |           | 210           |                          | 75                           | 160     | 26                         | 45      | 50                                      | 80      | 25                                 | 40      | 400                             |
|     |           | 240           | 125                      | 160                          | 30      | 50                         | 50      | 100                                     | 25      | 50                                 | 400     |                                 |
| 5   | 1350      | 300           | 125                      | 180                          | 39      | 60                         | 60      | 125                                     | 30      | 63                                 | 350×2   |                                 |
|     |           | 180           | 75                       | 160                          | 27      | 45                         | 50      | 80                                      | 25      | 40                                 | 400     |                                 |
|     |           | 210           | 125                      | 160                          | 30      | 51                         | 50      | 100                                     | 25      | 50                                 | 400     |                                 |
|     |           | 240           | 125                      | 180                          | 34      | 57                         | 60      | 125                                     | 30      | 63                                 | 350×2   |                                 |
| 6   | 1600      | 300           | 125                      | 180                          | 41      | 69                         | 60      | 125                                     | 30      | 63                                 | 350×2   |                                 |
|     |           | 180           | 125                      | 160                          | 31      | 52                         | 50      | 100                                     | 25      | 50                                 | 400     |                                 |
|     |           | 210           | 125                      | 180                          | 35      | 59                         | 60      | 125                                     | 30      | 63                                 | 350×2   |                                 |
|     |           | 240           | 125                      | 180                          | 39      | 66                         | 80      | 150                                     | 40      | 75                                 | 350×2   |                                 |
| 7   | 1800      | 300           | 160                      | 250                          | 48      | 81                         | 80      | 150                                     | 40      | 75                                 | 400×2   |                                 |
|     |           | 180           | 125                      | 180                          | 34      | 57                         | 60      | 125                                     | 30      | 63                                 | 350×2   |                                 |
|     |           | 210           | 125                      | 180                          | 39      | 65                         | 80      | 150                                     | 40      | 75                                 | 350×2   |                                 |
| 8   | 2000      | 240           | 125                      | 200                          | 43      | 74                         | 80      | 200                                     | 40      | 100                                | 400×2   |                                 |
|     |           | 180           | 125                      | 180                          | 37      | 63                         | 80      | 150                                     | 40      | 75                                 | 350×2   |                                 |
|     |           | 210           | 125                      | 200                          | 42      | 72                         | 80      | 200                                     | 40      | 100                                | 400×2   |                                 |
|     |           | 240           | 160                      | 250                          | 48      | 81                         | 100     | 200                                     | 50      | 100                                | 400×2   |                                 |

Note:  
 ① The main power wire size specified above is applicable for wire length less than 220m.  
 For main power wire length more than 220m, please calculate using the following formula:  
 Main power wire size(mm<sup>2</sup>) = [Actual wire length / 220] × [Wire size in above table]  
 ② Ventilation rate of fan shall be as below:

| Fan Size (Φmm) | Ventilation Rate (m <sup>3</sup> /h) |
|----------------|--------------------------------------|
| 200            | 540                                  |
| 250            | 930                                  |
| 300            | 1740                                 |
| 350            | 2460                                 |
| 400            | 3720                                 |

## Working environment of the elevator shall be as follow:

1. Ambient temperature shall be between 5°C to 40°C.
2. Maximum relative humidity is 90%, and the monthly mean minimum temperature should be below 25°C.
3. Supply voltage fluctuation shall be within  $\pm 7^\circ\text{C}$ .
4. Surrounding environment shall be free from explosive & corrosive hazard, anti-insulation and conductive particles atmosphere.

## About hoistway and machine-room:

1. Hoistway walls (including reinforced concrete ring beams) should be vertical, and the allowable deviation for the hoistway verticality is:  
 Total Height  $\leq 30\text{m}$ :  $0 \sim +25\text{mm}$ .  
 $30\text{m} < \text{Total Height} \leq 60\text{m}$ :  $0 \sim +35\text{mm}$   
 Total Height  $> 60\text{m}$ :  $0 \sim +50\text{mm}$
2. Hoistway walls shall be 200mm concrete walls.
3. Elevator hoistway is preferably not located in the space above accessible area. If the actual situation cannot meet the regulations, please contact us.
4. If elevator hoistway is of steel structure construction, please contact us.
5. Hoistway and machine room walls, floors and roofs should be able to absorb a large number of elevator operation noise.
6. Hoistway and machine room should not be located directly adjacent to bedrooms, classrooms, wards, library or any other places where low noise is required. Where such arrangements need to be imposed, the building contractors must be responsible for taking measures of sound insulation and cushioning.

## Work to be done by Building Contractors:

1. The preparatory work for elevator installation outlined below should be undertaken by building contractors in accordance with Hitachi drawing and applicable national or local codes and regulation.
2. Prepare hoistway with proper framing and enclosure, suitable pit of proper depth with drains and water-proofing if required, properly lighted and ventilated machine room of adequate size with concrete floor, access door, ladder and guards as required.
3. Provide and/or cut all necessary holes, chases, and openings and finish after equipment installation.
4. Supply and secure all supports, reinforced concrete slabs, etc., necessary for installation of the machinery, doors, buffers, etc.
5. Furnish all necessary cement and/or concrete for grouting-in of brackets, bolts, machine beams etc.
6. Prepare and erect suitable scaffolding and protective measures for the works in progress.
7. Furnish main for three-phase electric power and single-phase lighting supply to hoistway, following the instructions of the elevator contractors on outlet position and wire size.
8. Provide, free of charge, a suitable theft-proof storage area for materials and tools during erection work.
9. Supply electric power for lighting of work area, installation work, elevator testing and spray painting.
10. Suspension hook in the machine room with required loading as shown in this catalogue.

---

---

---

---

---

---

---

---

---

---

---

---

---

---

---

---

---

---

---

---

---

---

---

---

---

---

---

---

---

---

---

---

---

---

---

---

---

---

---

---

---

---

---

---

---

---

---

---

---

---

---

---

---

---

---

---

---

---

---

---

---

---

---

---

---

---

---

---

---

---

---

---

---

---

---

---

---

---

---

---

---

---

---

---

---

---

---

---

---

---